



**“Gheorghe Asachi” Technical University of Iasi, Romania**



---

## LIFE CYCLE ASSESSMENT OF WASTE MANAGEMENT AND RECYCLED PAPER SYSTEMS

**Cristina Ghinea<sup>1,2</sup>, Madalina Petraru<sup>1</sup>, Isabela Maria Simion<sup>1</sup>, Dana Sobariu<sup>1</sup>  
Hans Th. A Bressers<sup>3</sup>, Maria Gavrilescu<sup>1,4\*</sup>**

<sup>1</sup>“Gheorghe Asachi” Technical University of Iasi, Faculty of Chemical Engineering and Environmental Protection, Department of Environmental Engineering and Management, 73 Prof. dr. doc. Dimitrie Mangeron Str., 700050 Iasi, Romania

<sup>2</sup>Stefan cel Mare University of Suceava, Faculty of Food Engineering, 13 Universitatii Str., 720229 Suceava, Romania

<sup>3</sup>University of Twente, Faculty of Management and Governance, Twente Centre for Studies in Technology and Sustainable Development, P.O. Box 217, 7500 AE Enschede

<sup>4</sup>Academy of Romanian Scientists, 54 Splaiul Independentei, RO-050094 Bucharest, Romania

---

### Abstract

Municipal solid waste management is a matter experienced by the entire world, mostly encountered in urban areas as a result of population growth and increased income per capita. This issue always posed threats to environmental quality and human health, and continues to be one of the major environmental problems people continues to face. In the last few decades, the systems analysis techniques have been applied to manage the municipal solid waste (MSW) streams through a range of integrative methodologies so as to fulfill the necessity to ensure sustainable development of MSW.

The new Waste Directive 2008/98/EC it focuses on the need for choosing appropriate technologies that aim at improving the protection of human health and environment, promoting reuse and recycling, enhancing waste prevention programs via biowaste separate collection. New strategies at European level to promote life cycle thinking in waste management policies were motivated by the scarcity of resources.

In this paper Life Cycle Assessment (LCA) was applied to analyze and evaluate, from an environmental point of view, different municipal solid waste management (MSWM) scenarios and tissue paper manufacturing processes (two scenarios) based on virgin and recovered fibers.

*Key words:* fibers, life cycle, recycling, waste, tissue papers

*Received:* February, 2014; *Revised final:* August, 2014; *Accepted:* August, 2014

---

### 1. Introduction

Waste management represents an important issue for all countries due to the economic growth and increased urban agglomerations, which led to rapid increase in volume and types of waste (UNEP, 2009a, 2009b). Because of the variety of multifaceted factors which determine the fate of waste in the environment, solid waste management is a complex, multidisciplinary problem involving economic and technical aspects, normative constraint about the minimum requirement for the recycling and

sustainable development issues (Fiorucci et al., 2003; McDougall et al., 2001; OECD, 2007a).

The waste management systems start when waste is temporary stored in containers and includes whole life cycle of solid waste (collection, transport, process for recovery, treatment, elimination). Environmental pressures from generation, collection and processing of waste including emissions to air, soil and water have different impacts on the human health and the environment (Ghinea, 2012).

Waste management in Romania was less taken into account before 1990; the first statistics

---

\* Author to whom all correspondence should be addressed: E-mail: mgav@ch.tuiasi.ro

were introduced in 1993 by using a catalog of waste (Schiopu et al., 2007). European legislation on waste has been transposed into Romanian legislation, and finally the National Waste Management Strategy (NWMS) has been elaborated for setting waste management objectives aimed at creating the framework for developing and implementing an integrated waste management and the National Waste Management Plan (NWMP) for NWMS implementation (Simion et al., 2013). The prevalent method of waste disposal in Romania in 1998 was landfilling (99%) (NWMP, 2004).

Romania was granted some transition periods in order to fulfill the EU directives: for municipal waste sites by 2017; temporary storage of dangerous waste by 2009; storage of non-hazardous industrial waste by 2013. Several sites (177) should be closed down and the amount of waste landfilled should be gradually reduced (Ghinea, 2012). Romania has undertaken to cease storage activities in the 205 existing non-compliant municipal landfills operating in 2008 (ANPM, 2009). There are now ongoing ISPA funded projects or other funding sources, as well as public-private partnerships, provided for the implementation of integrated waste management system and the closure of stores opening line (ANPM, 2009).

Necessary measures should be planned so as to reach the most efficient method of recovery and recycling of waste and material types, sources of waste and different waste composition (NWMP, 2004). Romania is aware that the recovery and recycling will be successful only if collected and sorted materials will eventually be used in specific branches of industry. Therefore, production technology in glass, metal, paper, cardboard and plastic industries should be adapted to use these recovered materials (NWMP, 2004).

Nowadays recovered paper is the most important source of fibers used in papermaking with Europe as the global leader in paper recycling (ERPC, 2006; Stawicki and Read, 2010). Industry cannot, however, do this alone. Paper has to be collected separately from waste and other recyclables, a decision usually made by local authorities (ERPC, 2006).

Starting with 2000 the collection and recycling of waste paper increased with the initiative of CEPI to launch the "European Declaration Paper Recycling 2000-2005", a voluntary commitment of several professional associations with the main objective to achieve a recycling rate of 56% in 2005 compared to 48.9% in 1999. Waste paper recycling rate increased from 49.7% in 2000 to 56.4% in 2005. After the success of the first statement (2000-2005), a new voluntary commitment was signed for 2006-2010, which had a more ambitious goal, achieving a recycling rate of 66% paper and cardboard in 2010 (ERPA, 2005; ERPC, 2006). To ensure sustainable development in terms of solid waste management it

is necessary that society wastes are managed in an efficient manner, environmentally effective, economically affordable, and socially acceptable (Kirkeby, 2005; Omran and Gavrilescu, 2008; Thomas and McDougall, 2005).

Due to its complexity and the uniqueness, each waste management system is designed to satisfy particular objectives, such as waste policies and specific environmental targets (restricted to site specific constraints such as: waste composition, generation rates, geographical origin, installed treatment capacity, waste management technologies, stakeholders preferences) (Ghinea and Gavrilescu 2010a; Klang et al., 2008; Morrissey and Browne, 2004; Oropeza, 2006). Therefore, decision support models are necessary as holistic tools that minimize eco-efficient objective functions restricted to a set of logistical, technical, environmental and social constraints (Nouri et al., 2011; Oropeza, 2006).

In this paper we have used one model based on Life Cycle Assessment (LCA) (GaBi software) in order to **evaluate** the environmental impacts of various *solid waste management scenarios* proposed as *alternatives* to the municipal solid waste management system existent in Iasi in 2009, also to **evaluate** the environmental impacts of two different scenarios which includes *manufacturing of paper from virgin fiber* and *recycling of paper products to tissue paper*.

## 2. Life cycle assessment of municipal solid waste management system

Life cycle assessment method has fixed structure and is a standardized tool (ISO 14040:1997), which has the purpose of minimizing potential impact on the environment, human health and on resources. According to the ISO 14040:2006 a complete LCA study comprises four major phases, which are followed in this paper:

- **Goal Definition and Scoping** - include the objective and scope of study, system boundaries and the functional unit;

- **Inventory Analysis** - with a detailed compilation of all environmental inputs (resource and energy flows) and outputs (emissions and wastes);

- **Impact Assessment** – involves evaluation of environmental impacts from the inventory and establish environmental performance of the product;

- **Interpretation** – In this step the results of the inventory are interpreted (Frioriksson et al., 2002; Ghinea and Gavrilescu, 2010b).

In the recent years were developed several models based on LCA methodology and were applied for environmental evaluation of treatment and disposal methods included in municipal solid waste management systems (Banar et al., 2008; Blengini, 2009; Frioriksson et al., 2002; Ghinea and Gavrilescu 2010b; Moberg et al., 2005; Roy et al., 2009; Tsilemou and Panagiotakopoulos, 2007; Winkler and Bilitewski, 2007).

### *2.1. Municipal solid waste management system existent in Iasi, Romania (in 2009)*

In Iasi city municipal solid waste is collected by a public company of local interest. The separate collection of waste were carried out at in a pilot projects, usually for materials with high market values. Generally, the inhabitants must bring the solid waste to the collection, points distributed over the town at special locations close to their housing and place the waste in containers provided by the waste collection company. For separate collection in some collection points located in various parts of town there are special containers for waste fractions (Ghinea, 2012).

A new landfill was built in 2009 according with the legislation and put into operation namely Tutora landfill. In this landfill the collection and treatment of leachate is carried out according to the law (Schiopu and Ghinea, 2013). Also the collection of landfill gas is going to be set up. In 2009 a sorting station at Tutora was put into operation with a capacity of 29,000 t/y and a composting station was at that time under construction (Iasi County Council, 2009, Iasi County Council, 2011; Schiopu et al., 2009).

In March 2012 the composting process was also started at this point return manually, by operators windrows with pyramidal shape, a length of 30 m, height 2 m and width 3 m, wetting is made by the operator (waste of the windrow are 100% vegetable) in October 2012 was made windrows with green waste and household waste (25-30%) (Ghinea, 2012).

Tutora Landfill will be one of the 50 new landfills expected to be made in Romania, in line with EU regulations, under the National Waste Management Strategy and National Waste Management Plan approved by GD 1470 (2004).

This landfill should solve some problems highlighted in the Landfill Directive (EC Council Directive, 1999) "prevent or reduce as far as possible negative effects on the environment, in particular the pollution of surface water, groundwater, soil and air, and on the global environment, including the greenhouse effect, as well as any resulting risk to human health, from landfilling of waste, during the whole life-cycle of the landfill":

- eliminate the risk of pollution of groundwater and surface water as a result of the treatment of the leachate resulting from waste (leachate treatment plant is on site);
- reduce the leakage effects on surface water, due to pollutant load flowing through the landfill;
- reduce soil pollution, with plastic, paper or other light waste that can be taken by the wind and spread over adjacent surfaces due to selective collection of waste.

Municipal solid waste management system of Iasi (in 2008) consisted from temporary storage of solid waste in containers, collection and transport, and landfilling. Planning the alternatives for MSW

management system involves the consideration of specific and relevant methods for the treatment/elimination of solid waste. The most applied processes for the treatment of municipal solid waste are: recycling, composting, anaerobic digestion, incineration and landfilling (Ghinea, 2012).

Total quantities of waste generated in 2008 in Iasi were: *mixed household waste collected from households* (161045 t); *assimilable waste collected mixture of trade, industry* (23240 t); *waste from gardens and parks* (2162 t); *waste from markets* (2121 t); *street waste* (19834 t); *bulky waste* (48 t); quantities of waste collected selectively (239 t) (Iasi County Council, 2009).

The waste composition in Iasi in 2008 under the Long Term Investment Plan (Iasi County Council, 2009) was: *paper and cardboard* - 7.68%; *glass* - 4.35%; *metals* - 1.78%; *plastic* - 6.17%; *textiles*-3.16%; *biodegradable waste*-47.15%; *wood* - 1%; *others* - 28.71%.

### *2.2. Goal of the study, alternatives and system boundaries, functional unit*

The specific steps of LCA were taken in order to analyze the environmental impacts of the alternatives municipal solid waste management system of Iasi. Functional unit is represented by the amount of solid waste that was and will be generated in Iasi. The system boundaries are illustrated in Fig. 1. Municipal solid waste management scenarios were developed as alternatives to the waste management system existent in Iasi, Romania, in 2008, which included temporary storage of waste in containers, collection, transportation and landfilling processes (Ghinea et al., 2012).

The selection of treatment methods was conducted considering the amount of waste generated, composition of waste and the possibility to implement of the chosen treatment methods. Considering that over 40% of the municipal wastes generated in Iasi are represented by organic waste, so that composting and anaerobic digestion processes should be included in waste management scenarios (Ghinea, 2012).

Therefore, a composting plant with a capacity of 10,000 t/year was considered and the station will operate at its full capacity probably until 2018 (Ghinea et al., 2012; Iasi County Council, 2009). Although the amount of recyclable waste collected is very small comparative to the amount of waste generated, considerable efforts are made to implement the selective collection of solid waste by collecting each type of recyclable waste in different containers and by informing citizens about selective collection (FRD, 2011; Iasi County Council, 2009). A good selective collection of recyclable waste at source is a decisive step for the recycling process.

These recyclables could replace virgin materials to produce a particular product and to reduce emissions from the production for paper,

plastic from virgin materials and consumption of natural resources such as wood (Ghinea, 2012). Another process incineration can be implemented as one of the processes used to treat municipal solid waste, with energy recovery and metals recovery after slag treatment.

The alternatives incorporate certain categories of waste treatment methods as unit processes, resulting in the following scenarios: **scenario 1** (S1) - sorting, composting and landfilling; **scenario 2** (S2) - sorting, composting, anaerobic digestion and landfilling; **scenario 3** (S3) - sorting, composting, landfilling and incineration; and **scenario 4** (S4) - sorting, composting, and incineration (Fig. 2).

2.3. Inventory analysis

During the development of the inventory analysis phase, different data sources were consulted (literature, data collected from field, databases etc.). Some data used in this study were calculated according to the equations presented by Ghinea et al. (2012). All inputs and outputs were established for each process included in the scenarios.

2.4. Impact assessment

The life cycle impact assessment phase scope is to connect each life cycle inventory results to the corresponding environmental impacts (ISO, 2006a; Jolliet et al., 2003). The LCI results are classified into impact categories, each with a category indicator (ISO, 2006b; Jolliet et al., 2003).

Fig. 3 illustrates the environmental impact categories relevant for the waste management area (acidification potential (AP), eutrophication potential (EP), global warming potential (GWP), photochemical ozone creation potential (POCP), human toxicity potential (HTP), abiotic depletion (AD)).

The impact assessment stage was achieved with GaBi software, which includes different algorithms dedicated to perform a Life Cycle Impact Assessment. With the help of GaBi we developed plans (which represents the scenarios) based on processes and flows (all the inputs and outputs related to the system established in the inventory phase). After entering all inputs and outputs for each process and connecting the processes GaBi software allowed us the calculation of the material and energy balances in order to assess the environmental impacts.

GaBi 4 software (PE International, 2009) was used in different studies: (i) comparison of the environmental performance of different waste management systems and optimization (Buning, 2004); (ii) assessment and comparison of the environmental impact of corrugated board production by different component papers, based on virgin fibers and recycled fibers (Iosip et al., 2010); (iii) analysis and quantification of the environmental impacts associated with the production of packaging paper using 100% recovered paper as raw material (Iosip et al., 2012); (iv) evaluation of diverse municipal solid waste management systems developed for urban areas (for example, Iasi city, Romania), as well as to emphasize the importance of system boundaries for life cycle impact assessment (Ghinea et al., 2012); (v) evaluation of the climate change impact of waste management systems and paper manufacturing process from recovered fibres (Ghinea et al., 2011); (vi) determination of environmental performances of tissue products manufacturing process associated with the use of virgin fibres and recycled fibres etc. (Petraru et al., 2011). In Table 1, the impact categories from all LCA methodologies chosen for evaluation of municipal solid waste management scenarios and manufacturing of tissue paper scenarios are presented.

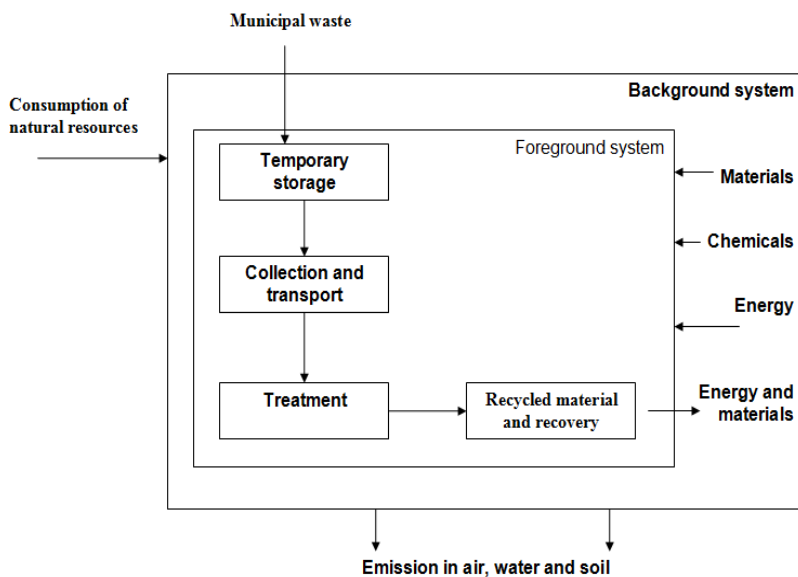
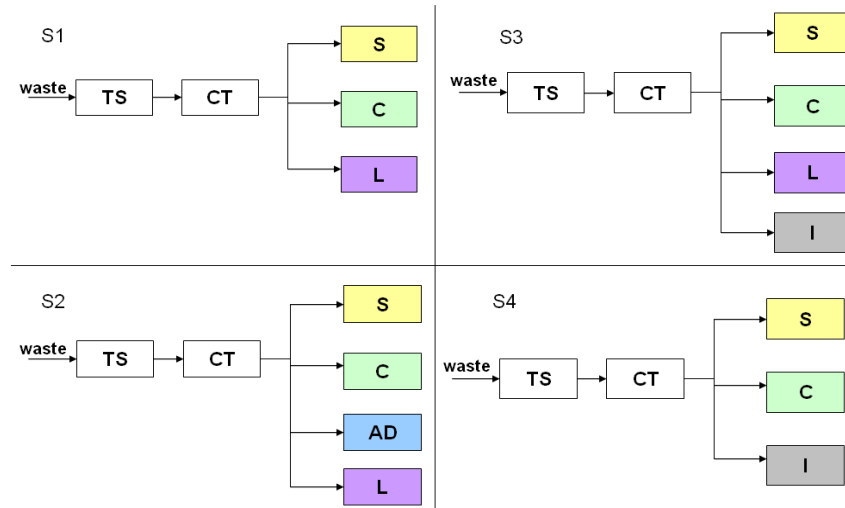
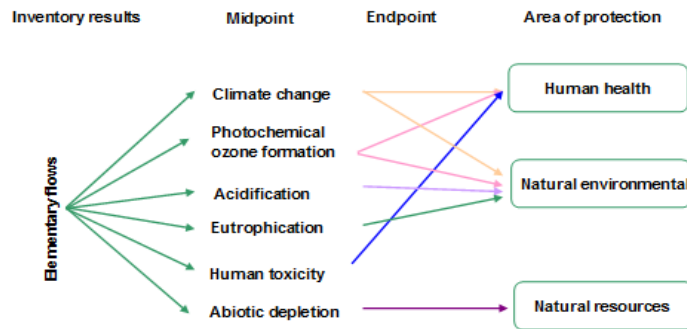

Fig. 1. System boundaries for municipal solid waste management system (Ghinea, 2012)



**Fig. 2.** Scenarios analyzed: scenario 1 (S1), scenario 2 (S2), scenario 3 (S3), scenario 4 (S4); (TS- temporary storage, CT- collection and transport, S - sorting, L –landfilling, C – composting, AD – anaerobic digestion, I - incineration)



**Fig. 3.** Impact categories – midpoint and endpoint level (Ghinea, 2012)

**Table 1.** List of impact categories from all methodologies used

Methodology	Impact categories	Abbreviation
CML2001	Abiotic Depletion Potential	ADP
	Acidification Potential	AP
	Eutrophication Potential	EP
	Global Warming Potential	GWP
	Human Toxicity Potential	HTP
	Photochemical Ozone Creation Potential	POCP
CML 96	Acidification potential	AP
	Eutrophication potential	EP
	Global warming potential (GWP 100 years)	GWP 100
	Global warming potential (GWP 20 years)	GWP 20
	Global warming potential (GWP 500 years)	GWP 500
	Human Toxicity Potential	HTP
EDIP 1997	Photochemical Ozone Creation Potential	POCP
	Acidification potential	AP
	Global Warming Potential	GWP
	Nutrient enrichment potential	NE
	Photochemical oxidant potential (high NOx)	POP high NOx
EDIP 2003	Photochemical oxidant potential (low NOx)	POP low NOx
	Acidification potential	AP
	Global Warming	GW
	Photochemical ozone formation - impact on human health and materials	POF-IH
	Photochemical ozone formation - impact on vegetation	POF-IV
EI95	Terrestrial eutrophication	TE
	Carcinogenic substances	CS
	Heavy metals	HM
	Winter smog	WS

2.5. Interpretation

GaBi 4 allowed us the calculation of material and energy balances in order to assess the environmental impacts. In Fig. 4 the environmental impacts of scenarios considering CML 2001 methodology. The negative values obtained for the impact categories means positive impacts to the environment.

The hierarchy of environmental impacts resulting from application of the methodology CML 2001, starting from

*low positive impacts*  $\xrightarrow{to}$  *positive impacts*

were: for **GWP**: S2>S4> S1> S3; for **EP**: S2> S4> S3> S1; for **POCP**: S2>S1> S4> S3; for **HTP**: S1> S4> S2> S3.

According to Ghinea et al. (2012) the system boundaries has a major influence on the results of life cycle assessment studies. For the assessment were taken into account diesel emissions, recycling of the waste sorted, substitution of electricity and heat with those produced from landfill biogas, as well as the substitution of synthetic soil fertilizers with compost, so that the impacts associated to the production of synthetic fertilizers are avoided, electricity obtained in the anaerobic digestion process, which can substitute the electricity produced by conventional methods, energy recovery and metals recovery after slag treatment in the incineration process.

The evaluation and analysis of the selected scenarios revealed the following environmental impacts generated by the involved processes:

- *composting* process has the greatest influence on **AP** and **POCP** impact categories;
- *anaerobic digestion* process affects **EP** and **POCP** impact categories in a small extent;
- large contribution to **GWP** and significant influence on **EP** and **POCP** lies with *incineration*;
- *landfilling* proved to have the highest influence on **EP** and **GWP**;
- *temporary storage, collection and transport* have a low contribution to all impact categories.

The environmental impacts of the scenarios evaluated with CML 96, EDIP 1997, EDIP 2003, EI95 methodologies included in GaBI software are illustrated in Fig. 5. The values obtained for each category of impact in different measurement units are normalized so that the environmental impact categories to be compared and illustrated on a single graphic. If the values of impact categories are positive that means negative impacts on the environment. The hierarchy of environmental impacts resulting from application of different LCA methodologies considering

*positive impacts*  $\xrightarrow{to}$  *negative impacts*

were: **CML 96**: S3> S1>S2> S4; **EDIP 1997**: S3> S1>S2> S4; **EDIP 2003**: S3> S1>S2> S4; **EI95**: S3> S1>S2> S4.

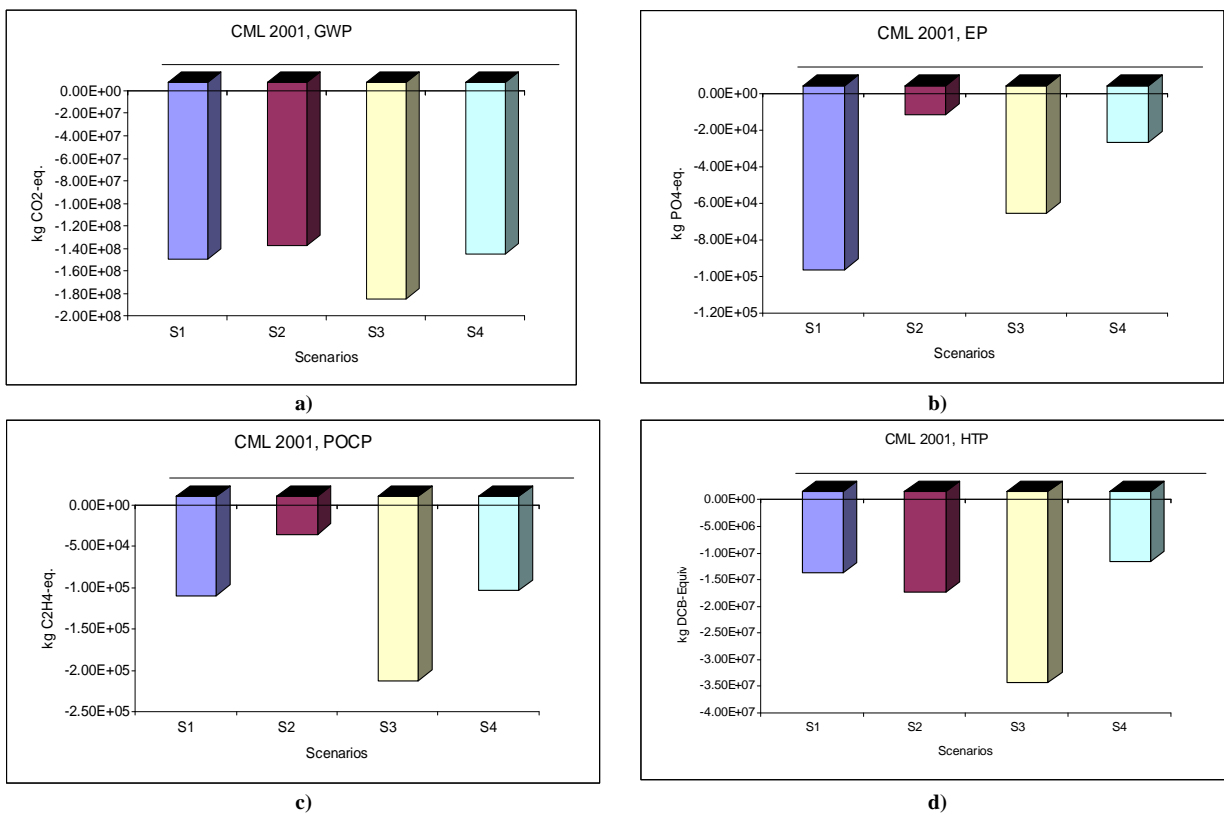

Fig. 4. Environmental impacts of scenarios, CML 2001: a) global warming potential; b) eutrophication potential; c) photochemical ozone creation potential; d) human toxicity potential

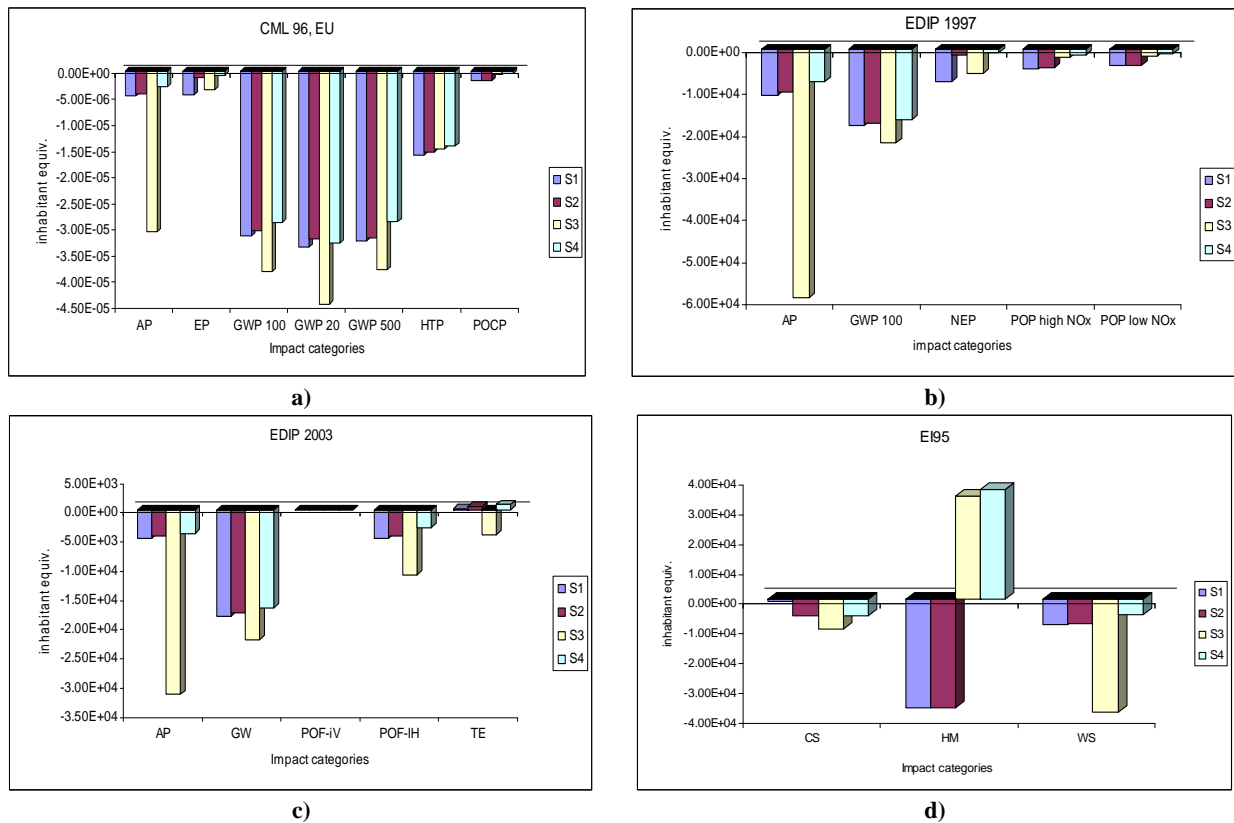

Fig. 5. Environmental impacts of waste management alternatives: a) CML 96 methodology; b) EDIP 1997 methodology; c) EDIP 2003 methodology d) EI95 methodology

Our results indicate that **scenario 3** (sorting, composting, landfilling and incineration) is *the most environmental friendly scenario*.

### 3. Life cycle assessment of recycled paper system

In the course of time the pulp and paper industry was considered one of the most consuming industries in the world, in terms of natural resources and energy, and also a significant contributor to pollutant discharges into the environment (Cheremisinoff and Rosenfeld, 1998; Gavrilescu and Bobu, 2009; Ince et al., 2011; Petraru and Gavrilescu, 2011; Petraru et al., 2011; Petraru, 2012). In the recent years, the Europe is considered the global leader in paper recycling and the recovered paper is the most important source of fibers used in papermaking (ERPC, 2006; Stawicki and Read, 2010). It is well known that industry cannot do this alone. There must be a connection between waste management system and paper industry, and not only, the separate collection of paper from waste and other recyclables is often a decision made by local authorities (ERPC, 2006). The sustainable exploitation of natural resources can be achieved by an efficient use of recovered fibers, which can also supports sustainable development (Petraru, 2012; Petraru et al., 2011; Rebitzer, 2005).

With a strong commitment to sustainable production the European paper industry has maintained a strong position in the global

marketplace with (Gavrilescu et al., 2008): more than 1000 existing plants; generating directly or indirectly around 4 million jobs; net sales of ca. €78.6 billion; employing 259,100 people; contributing about €21 billion to the EU's Gross Domestic Product.

The pulp for papermaking may be produced from both virgin fibers by chemical or mechanical means or from recovered paper (IPPC, 2001). The recycling of wood fibers can be done for several times and a paper product can be obtained from recycled fibers alone. Before recycling step paper and cardboard must be collected and sorted at source, in order to separate white papers from brown papers. The paper quality will decrease if the papers and board are mixed with other waste. There are different types of paper used for the production of graphic papers and others for the production of packaging materials (Holik, 2006; Petraru, 2012; Petraru et al., 2011; Stawicki and Read, 2010). Several quality criteria must be fulfilling by the recovered paper:

- foreign elements such as: metals, wood, glass, rubber, celluloid, leather, textile strings, plastic, wax, polythene and other synthetic resins, waterproof paper are not accepted;
- the paper must not contain other waste, toxic products packages, carbon black;
- the paper must not be decayed or musty (Ghinea et al., 2011; Petraru, 2012; Vrancart, 2008).

Recovered fibers has become an indispensable raw material for the paper manufacturing industry because of the favorable price of recovered fibers in

comparison with the corresponding grades of market pulp and the encouragement of wastepaper recycling by many European countries (Petruaru, 2012; Stawicki and Read, 2010). For effective use of recovered paper it is necessary to collect, sort and classify the materials into suitable quality grades so after collection recovered paper is brought to the collection yards where it is sorted and compacted by baling machines. Detrimental substances as plastics, laminated papers are removed before balling as well as possible (Hyytiä, 2004; IPPC, 2001; Petruaru, 2012).

The recovered paper processing system varies according to the requirements of the final product, for example packaging paper, newsprint or tissue paper and the type of furnish used.

Recycled fibers (RCF) processes can be divided in two main categories (Demchishina, 2011; IPPC, 2001; Paper Task Force, 1995; Petruaru, 2012):

- Processes without deinking that consists exclusively in mechanical cleaning (products like testliner, corrugating medium, uncoated board and cardboard);

- Processes with mechanical cleaning and de-inking (products like newsprint, tissue, printing and copy paper, magazine papers, coated board and cardboard or market DIP).

When using recovered paper to produce a high quality tissue the requirements are higher than the case of other products so there is the need for a processing in such a way that not only coarse contaminants, but also printing inks, stickies, fines and fillers have to be removed. That means about 30-100% more recovered paper is needed compared with the finished stock which can lead to a relatively high amount of waste to handle and treat (Holik, 2006; IPPC, 2001; Petruaru, 2012).

Recovered fibers used in the manufacturing process are, usually, a blend of sorts I and II: - Sort I consists of recyclable materials and non-print paper and paperboard unwritten (white paper and paperboard, printed yet unwritten and cannot be used); - Sort II consists of reusable materials from paper and paperboard, printed or written (paper and paperboard, white, printed or written material, newspapers, magazines, books, brochures, books and other materials from the collection of papers and other such records) (IPPC, 2001).

Due to the fact that tissue paper is discarded after use, modeling open loop recycling of paper products to tissue paper is complex because it is impossible to recycle paper, recover and recycle again for a number of times (Petruaru, 2012).

### 3.1. Goal of the study, system boundaries and functional unit

Since waste paper holds a significant percentage in the total of waste, it was considered opportune the evaluation of the environmental impact generated by a particular scenario entailing paper manufacturing from recycled fibers (RCF). Having in

mind the goal of this study, we applied LCA methodology to evaluate the environmental performance of tissue products manufacturing process subjected to changes in the context of pollution prevention using two scenarios which have a common feature the fact that the raw material – virgin fibers made from spruce wood was substituted with recycled fibers from recovered paper. The raw materials necessary for paper manufacturing are virgin fibers (scenario VFB) or recovered paper (scenario RCF), water and some chemical additives. *The functional unit considered was one tonne of tissue paper.* As unit processes included in the paper manufacturing from recycled fibers we considered: *transportation* of materials to and from the paper mill, *manufacturing* process itself, *chemicals consumption, energy and natural gas consumption* (Fig. 6).

### 3.2. Inventory analysis

For each of the tissue manufacturing scenarios, inventories of significant environmental flows to and from environment, and internal material and energy flows were determined from literature, statistics, and companies' reports, GaBi software databases and then were calculated and converted to values that relate to the functional unit of each system (Holik, 2006; IPPC, 2000; IPPC, 2001; Madsen, 2007; PE International, 2009; Petruaru et al., 2011).

The inventory collected for each of the tissue paper systems consist in information regarding: raw materials; chemicals; energy; water use; steam; emissions to air, water and soil; products; solid waste; waste water (Petruaru et al., 2011).

Starting from the data provided by the specialists in the pulp and paper area the demand for raw materials was determined for each scenario (Petruaru et al., 2011). The demand of raw materials for manufacturing of 1 tonne of products is as follows: 1.02 tonne pulp from virgin fibers, when the scenario VFB is concerned and 1.5 tonnes recycled fibers, when the scenario RCF is considered (Petruaru et al., 2011).

### 3.3. Impact assessment, results and discussions

GaBi 4 was also used to evaluate the paper manufacturing process. The environmental impact of recovered paper manufactured process is due to solid waste generation, emissions to water and atmospheric emissions related to energy generation. Compared with the manufacturing process that uses virgin fibers as raw materials, the paper manufacturing from recycled fibers induces positive impacts on the environment. All data from the inventory step together with those from GaBi database helped us to quantify the impact categories associated to each scenario developed for tissue paper manufacturing.

In a first approach, we have applied the CML 2001 Europe, followed by CML 1996, CML 96,



EDIP 1997, EDIP 2003 and EI95 methodology. Fig. 7 shows a LCIA comparison of scenarios VFB and RCF using CML midpoint indicators related to one tonne of tissue products which is chosen as functional unit for these two scenarios. The results are presented in non-normalized values for Europe.

As it can be observed from Fig. 7, the tissue paper manufacturing process that uses virgin fiber as raw material (scenario VFB) has the highest value to all impact categories, due to the high demand of energy and natural gas consumption for the paper manufacturing process. The main cause of the differences between the environmental impacts of the proposed scenarios lies in the complexity of the manufacturing process, the resources and the additives demands, the energy demand for the manufacturing process and the transportation of the materials to the mill.

A detailed analysis showed that the energy resources consumption has a major contribution to impact categories such as: Global Warming Potential

(GWP), Human Toxicity Potential (HTP), Photochemical Ozone Creation Potential (POCP). CO<sub>2</sub> emissions which result from energy, natural gas, and from the tissue paper manufacturing (steam production step) have the most important contribution. Heavy metals were found as major contributors to HTP impact category. The value of POCP impact is highly determined by the concentration of VOC, NO<sub>x</sub>, SO<sub>2</sub> in gaseous emissions.

For both scenarios we found that the tissue manufacturing has a high contribution to the eutrophication potential (EP) due to nutrient content of raw material (especially in scenarios which involve virgin fibers as raw materials), and also wastewater treatment emissions.

Similar results are obtained in other methodologies such as CML 96 methodology (Fig. 8 a), EDIP 1997 methodology (Fig. 8b), EDIP 2003 methodology (Fig. 8c) and EI95 methodology (Fig. 8d).

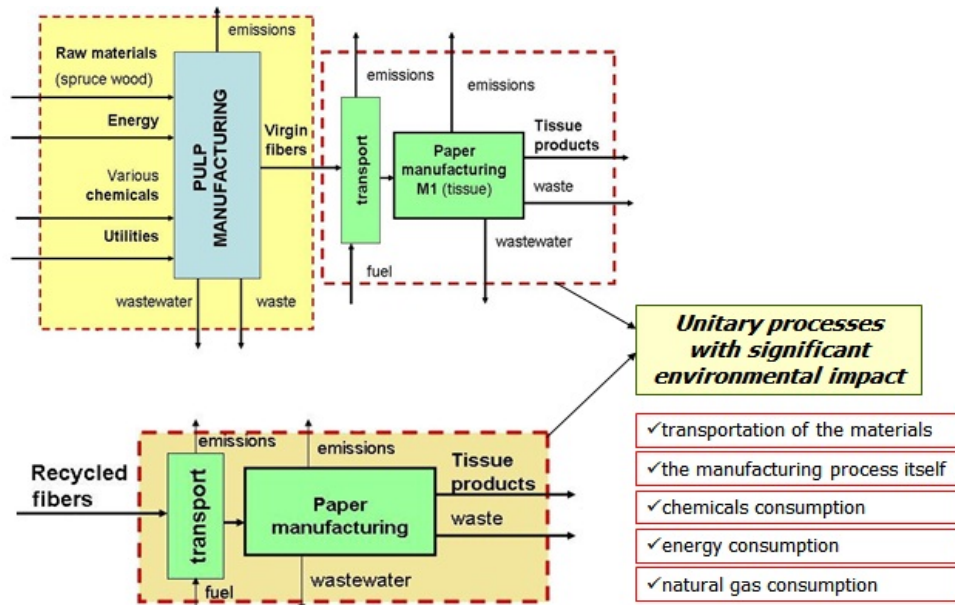
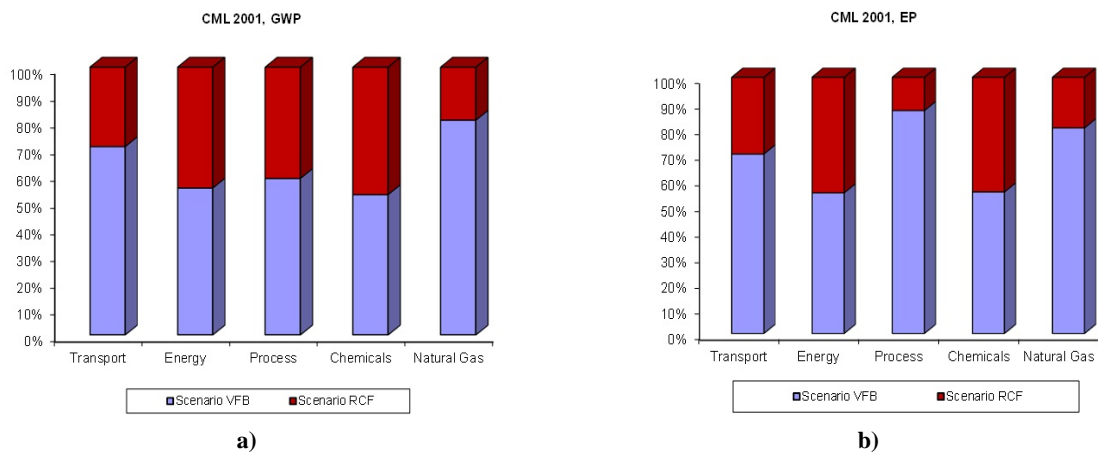

Fig. 6. Life Cycle of tissue paper manufactured from virgin fibers and recovered paper (Petru, 2012)



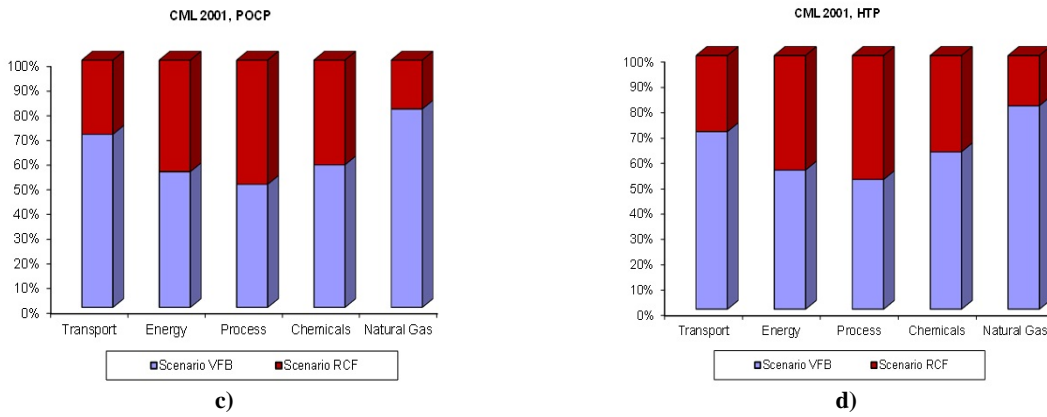

Fig. 7. Tissue manufacturing process impact (virgin and recovered) on a) global warming potential; b) eutrophication potential; c) photochemical ozone creation potential; d) human toxicity potential

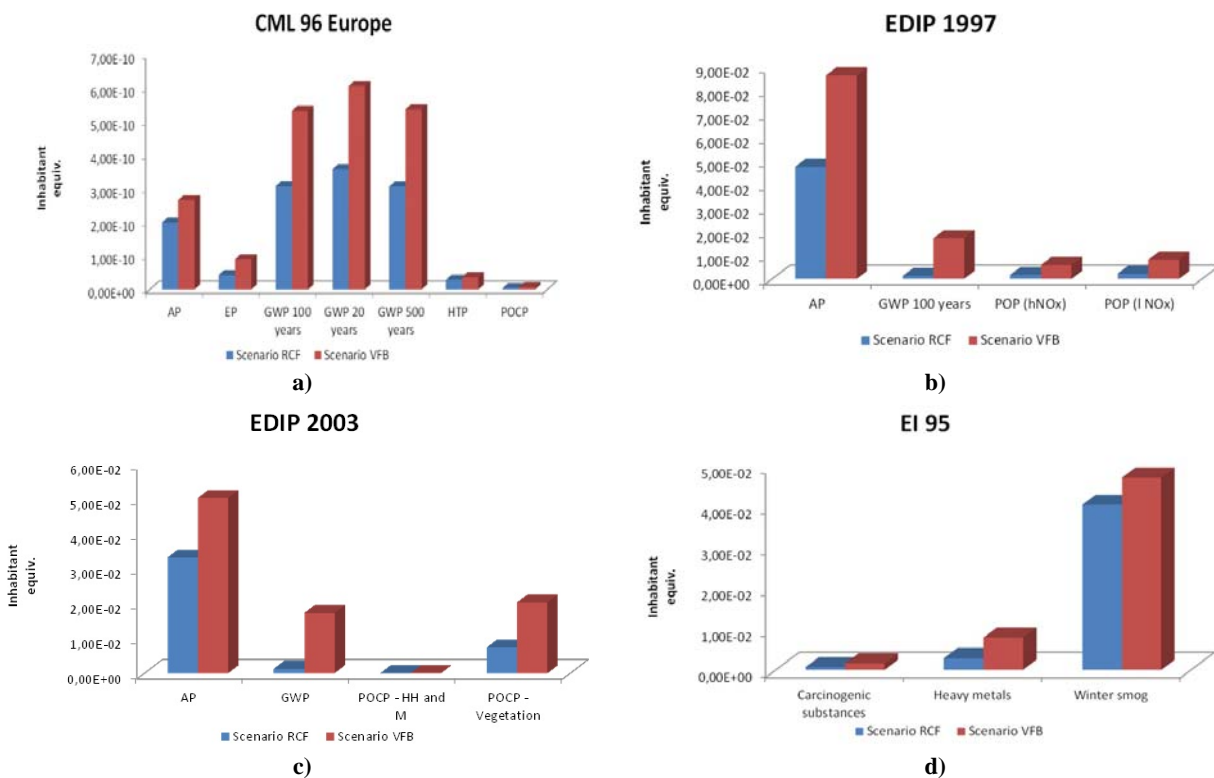

Fig. 8. Environmental impacts of tissue products from virgin and recovered fiber: a) CML 96 methodology; b) EDIP 1997 methodology; c) EDIP 2003 methodology d) EI95 methodology

CML 96 Europe shows the same tendencies at the impact categories values with the focus on climate change due to the substances that gradually decompose and become inactive in the long run (20, 100 and 500 years). Longer horizons are used to assess the cumulative effect of greenhouse gas emissions, while shorter horizons provide an indication of short-term effects.

Similar to CML 2001 methodology, scenario RCF is considered the most suitable to be implemented due to the benefits brought especially in EP, AP and POCP impact categories, as a consequence of reduced SO<sub>2</sub>, NO<sub>x</sub> and VOC emissions and a low impact allocated to the reuse of the fibers.

From the plots it can be observed that CO<sub>2</sub> emissions have a higher contribution to global warming in scenario VFB than in scenario RCF. Acidification potential is the consequence of high releases of nitrogen (NO<sub>x</sub> and NH<sub>3</sub>) and sulphur (SO<sub>2</sub>) to the air, while the substances contributing to photochemical ozone formation exert a relatively high impact on vegetation.

The analysis with EI 95 indicator showed that the use of virgin fibers leads to higher impacts on the environment due to the fact that in the process there are not reused residues or waste, while the other scenario include recovered paper in the process of paper manufacturing, taken into account the allocated

impact from the first stage of the process, namely the pulping of virgin fibers.

#### 4. Conclusions

Solid waste management continues to be a topical issue discussed and reviewed internationally. Interdisciplinary studies have been conducted worldwide to assess the sustainability of solid waste management, while several models have been developed in recent decades for this purpose, based on different methodologies taking into account environmental, economic and social criteria. These models are considered as decision support tools that help decision makers in determining the suitable alternative in regard to waste management strategies.

In this paper four municipal solid waste management scenarios were developed and evaluated from environmental point of view using one tool (GaBI) which is based on Life Cycle Assessment methodology. The treatment methods included in the scenarios were chosen based on waste composition and quantities and on existent technologies. Scenarios were developed as alternatives to the municipal solid waste management system existent in Iasi, Romania in 2009 in order to fulfill the requirements imposed by the European and Romanian legislation and to protect the environment. The most suitable scenario for implementation from environment point of view resulted after the evaluation with LCA is scenario 3 which included waste treatment methods like: sorting, composting, landfilling and incineration. In the future studies will be presented the evaluation of the developed scenarios using methodologies such as cost benefit analysis and multicriteria evaluation, considering not only the environment issue but also economic, technical aspects etc.

Efforts are being made everywhere in Europe and not only, for obtaining a recycling society that seeks to avoid losses and uses waste as resources. The key to successful development of waste recycling option is the design of waste management systems adapted to local needs and traditions.

For this purpose in this study it was also evaluated the environmental performances of tissue paper manufacturing scenarios developed for the Romanian case study, which propose the use of recycled fibers from recovered paper as raw materials, instead of virgin fibers. Environmental impact assessment of the two considered scenarios revealed positive values emphasizing a negative impact on the environment. The scenario with recovered fibers as raw materials is considered the suitable alternative for implementation into a process, when compared to the scenario that uses virgin fibers. The main cause of the differences between the environmental impacts of the proposed scenarios lies in the complexity of the manufacturing process, the resources and the additives demands, the energy demand for the manufacturing process and the transportation of the materials to the mill.

Future studies addressing the evaluation of manufacturing of plastics from recovered waste plastics or manufacturing of glass from recovered glass can be useful, if the integration of these systems in a total waste management system would be considered opportune. Our studies demonstrate that the environmental evaluation of any waste management system, which includes also the manufacturing processes of recycled materials, will provide a more comprehensive representation of real systems.

#### Acknowledgment

This work was supported by EURODOC "Doctoral Scholarships for research performance at European level" project, financed by the European Social Fund and Romanian Government; University of Twente, Twente Centre for Studies in Technology and Sustainable Development (CSTM); GaBi4: Software and database for Life Cycle Engineering, PE INTERNATIONAL GmbH and by a grant of the Romanian National Authority for Scientific Research, CNCS – UEFISCDI, project number PN-II-ID-PCE-2011-3-0559 IDEI Project, contract 265/2011.

#### References

- ANPM, (2009), Annual report on environmental conditions in Romania 2008, Chapter 7, Waste, On line at: [http://www.anpm.ro/Files/Capitolul%207%20-%20Deseuri\\_20091227450.pdf](http://www.anpm.ro/Files/Capitolul%207%20-%20Deseuri_20091227450.pdf).
- Banar M., Cokaygil Z., Ozkan A., (2009), Life cycle assessment of solid waste management options for Eskisehir, Turkey, *Waste Management*, **29**, 54-62.
- Blengini G.A., (2009), Life cycle of buildings, demolition and recycling potential: A case study in Turin, Italy, *Building and Environment*, **44**, 319-330.
- Buning G., (2004), *Development of an LCA-based Waste Management Model and its Application to optimise Sydney's domestic Waste Management*, Department of Environmental Engineering in cooperation with the Centre for water and waste technology, University of Applied Sciences, Diploma Thesis.
- Chermisinoff N., Rosenfeld P.E., (1998), *The Best Practices in the Wood and Paper Industries*, Elsevier.
- Demchishina M., (2011), *Soft ECF-bleaching of Softwood Pulps*, Master's Thesis, Lulea University of Technology.
- EC Council Directive, (1999), Council Directive 1999/31/EC of 26 April 1999 on the landfill of waste, *Official Journal of the European Communities*, L 182/1, 16.7.1999, Brussels.
- ERPA, (2010), CEPI Annual statistics 2010, European Recovered Paper Association, On line at: [http://www.erpa.info/download/CEPI\\_annual\\_statistics\\_2010.pdf](http://www.erpa.info/download/CEPI_annual_statistics_2010.pdf).
- ERPC, (2006), European declaration European Declaration on Paper Recycling 2006 – 2010 - Monitoring Report 2006, European Recovered Paper Council, On line at: [http://www.erpa.info/images/EDPR\\_Annual\\_Report\\_WEB.pdf](http://www.erpa.info/images/EDPR_Annual_Report_WEB.pdf).
- Fiorucci P., Minciardi R., Robba M., Sacile R., (2003), Solid waste management in urban areas development and application of decision support systems, *Resource, Conservation and Recycling*, **37**, 301-328.

- FRD, (2011), *Solid Waste Management and Recycling in Romania*, FRD Center Market Entry Services, Bucharest, Romania.
- Frioriksson G.B., Johnsen L.T., Bajarnadottir H.J., Sletnes L.H., (2002), *Guidelines for the use of LCA in the waste management sector*, Technical report, Nordtest Project no. 1537-01.
- Gavrilescu M., Teodosiu C., Gavrilescu D., Lupu L., (2008), Strategies and practices for sustainable use of water in industrial papermaking processes, *Engineering in Life Sciences*, **8**, 99-124.
- Gavrilescu D., Bobu E., (2009), Driving forces and barriers for sustainable use of recovered paper in papermaking, *Environmental Engineering and Management Journal*, **8**, 1129-1134.
- GD 1470, (2004), Governmental Decision no. 1470 of 9 September 2004 approving the national waste management strategy and national waste management plan, *Romanian Official Monitor*, Nr. 954 of 18 October, 2004.
- Ghinea C., Gavrilescu M., (2010a), Models for sustainable waste management, *The Bulletin of the Polytechnic Institute from Iasi, Chemistry and Chemical Engineering Section*, **LVI (LX)**, 21-36.
- Ghinea C., Gavrilescu M., (2010b), Decision support models for solid waste management – an overview, *Environmental Engineering and Management Journal*, **9**, 869-880.
- Ghinea C., Petraru M., Gavrilescu M., Bressers H., (2011), Waste management and recovery of fibres – the impact on climate change, IGS-SENSE Conference Resilient Societies - Governing Risk and Vulnerability for Water, Energy and Climate Change, 19 - 21 Octombrie 2011, Universitatea Twente, Enschede, Olanda, On line at: [http://www.utwente.nl/igs/conference/2011\\_resilient\\_societies/Papers%20and%20presentations%20CLIMATE%20CHANGE/Postersession\\_Paper%20Ghinea\\_IG\\_S\\_Conference.pdf](http://www.utwente.nl/igs/conference/2011_resilient_societies/Papers%20and%20presentations%20CLIMATE%20CHANGE/Postersession_Paper%20Ghinea_IG_S_Conference.pdf).
- Ghinea C., (2012), *Waste management models and their application to sustainable management of recyclable waste*, PhD Thesis, Gheorghe Asachi Technical University of Iasi, Romania.
- Ghinea C., Petraru M., Bressers H., Gavrilescu M., (2012), Environmental Evaluation of Waste Management Scenarios – Significance of the Boundaries, *Journal of Environmental Engineering and Landscape Management*, **20**, 76-85.
- Holik H., (2006), *Handbook of Paper and Board*, WILEY-VCH Verlag GmbH & Co. KGaA, Weinheim.
- Hyytiä H., (2004), *Guidelines on bat for production of pulp using elemental chlorine*, Finland.
- Iasi County Council, (2009), Long-term investment plan for the period 2008-2038 on integrated waste management, On line at: <http://www.icc.ro/activitate/mediu/MasterP/MasterPlan.pdf>.
- Iasi County Council, (2011), *Report on the Study of Environmental Impact Assessment, Integrated waste management system in Iasi*.
- Ince B.K., Cetecioglu Z., Ince O., (2011), *Pollution Prevention in the Pulp and Paper industries*, In: *Environmental Management in Practice*, Broniewicz E. (Ed.), In Tech Publishing, 224-246.
- Iosip A., Hortal M., Dobón A., Bobu E., (2010), Comparative environmental impact assessment of corrugated board production, *Environmental Engineering and Management Journal*, **9**, 1281-1287.
- Iosip A., Hortal M., Dobón A., Bobu E., (2012), Assessing environmental impact of packaging paper production based on recycled fibre raw material, *Environmental Engineering and Management Journal*, **1**, 99-108.
- IPPC, (2000), *Technical Guidance for the Pulp and Paper Sector*, Integrated Pollution Prevention and Control, European Commission.
- IPPC, (2001), Reference Document - Best available techniques in the pulp and paper industry, Integrated Pollution Prevention and Control, European Commission.
- ISO, (1997), Environmental management - Life cycle assessment - Principles and framework, (ISO 14040:1997), European Standard EN ISO 14040, The International Organization for Standardization, Geneva, Switzerland.
- ISO (2006a), Environmental management – Life cycle assessment – Principles and framework (ISO 14040:2006), European Standard EN ISO 14040, The International Organization for Standardization, Geneva, Switzerland.
- ISO, (2006b), Environmental management - Life cycle assessment - Life cycle impact assessment, (ISO 14044:2006), European Standard EN ISO 14040, The International Organization for Standardization, Geneva, Switzerland.
- Jolliet O., Margni M., Charles R., Humbert S., Payet J., Rebitzer G., Rosenbaum R., (2003), IMPACT 2002+: A New Life Cycle Impact Assessment Methodology, *International Journal of Life Cycle Assessment*, **8**, 324-330.
- Kirkeby J.T., (2005), *Modelling of life cycle assessment of solid waste management systems and technologies*, PhD thesis, Institute of Environment & Resources, Technical University of Denmark.
- Klang A.B., Vikman P.A., Brattebo H., (2008), Sustainable management of combustible household waste – Expanding the integrated evaluation model, *Resource, Conservation and Recycling*, **52**, 1101-1111.
- Madsen J., (2007), *Life Cycle Assessment of Tissue Products, Final Report*, Environmental Resources Management.
- McDougall F., White P., Franke M., Hindle P., (2001), *Integrated Solid Waste Management: a Life Cycle Inventory*, 2<sup>nd</sup> Edition, Blackwell Science.
- Moberg A., Finnveden G., Johansson J., Lind P., (2005), Life cycle assessment of energy from solid waste – part 2: landfilling compared to other treatment methods, *Journal of Cleaner Production*, **13**, 231-240.
- Morrissey A., Browne J., (2004), Waste management models and their application to sustainable waste management, *Waste Management*, **24**, 297-308.
- Nouri D., Sabour M.R., Ghanbarzadeh L., (2011), Environmental and technical modelling of industrial solid waste management using analytical network process; A case study – Gilan Iran, *World Academy of Science, Engineering and Technology*, **81**, 130-136.
- NWMP, (2004), *National Waste Management Plan*, Ministry of Environment and Water Management, Bucharest, Romania.
- OECD, (2007), *Guidance Manual on Environmentally Sound Management of Waste*, Organisation for Economic Development and Co-Operation, Paris, France.
- Omran A., Gavrilescu M., (2008), Municipal solid waste management in developing countries: a perspective on Vietnam, *Environmental Engineering and Management Journal*, **7**, 469-478.

- Oropeza E.M., (2006), *Suwamas: A Decision support model for sustainable waste management systems*, PhD Thesis, University Dortmund.
- Paper Task Force, (1995), *Environmental comparison of bleached kraft pulp manufacturing technologies*, Environmental Defense Fund.
- PE International, (2009), *Handbook for Life Cycle Assessment (LCA) Using the GaBi Education Software Package*, Germany.
- Petraru M., Gavrilesu M., (2011), Transition towards a sustainable economy based on industrial ecology principles: Romanian case study, *Bulletin of the Polytechnic Institute of Iasi, Chemistry and Chemical Engineering Section*, **57**, 133–145.
- Petraru M., Ghinea C., Bressers H., Gavrilesu M., (2011), Analysis of Environmental Impact for Industry Products. Case Study: Paper Manufacturing, *Bulletin of the Polytechnic Institute of Iasi, Section Chemistry and Chemical Engineering*, **57**, 63-74.
- Petraru M., (2012), *Integration of economics and pollution prevention practices for a sustainable industry*, PhD Thesis, Gheorghe Asachi Technical University of Iasi, Romania.
- Rebitzer G., (2005), Enhancing the application efficiency of life cycle assessment for industrial uses, Lausanne, EPFL, On line at: [http://biblion.epfl.ch/EPFL/theses/2005/3307/EPFL\\_TH3307.pdf](http://biblion.epfl.ch/EPFL/theses/2005/3307/EPFL_TH3307.pdf).
- Roy P., Ijiri T., Nei D., Orikasa T., Okadome H., Nakamura N., Shiina T., (2009), Life cycle inventory (LCI) of different forms of rice consumed in household in Japan, *Journal of Food Engineering*, **91**, 49-55.
- Schiopu A.M. Apostol I., Hodoreanu M., Gavrilesu M., (2007), Solid waste in Romania: management, treatment and pollution prevention practices, *Environmental Engineering and Management Journal*, **5**, 451-465.
- Schiopu A.M., Robu B.M., Apostol I., Gavrilesu M., (2009), Impact of landfill leachate on soil quality in Iasi county, *Environmental Engineering and Management Journal*, **8**, 1155-1164.
- Schiopu A.M., Ghinea C., (2013), Municipal solid waste management and treatment of effluents resulting from their landfilling, *Environmental Engineering and Management Journal*, **12**, 1699-1719.
- Stawicki B., Read B., (2010), *The Future of Paper Recycling in Europe: Opportunities and Limitations*, COST Office, On line at: <http://www.cost.eu/media/publications/10-19-The-Future-of-Paper-Recycling-in-Europe-Opportunities-and-Limitations>.
- Thomas B., McDougall F., (2005), International expert group on life cycle assessment for integrated waste management, *Journal of Cleaner Production*, **13**, 321-326.
- Tsilemou K., Panagiotakopoulos D., (2007), Solid waste management systems assessment: the municipality's point-of-view, *Environmental Engineering and Management Journal*, **6**, 51-57.
- Simion I.M., Ghinea C., Maxineasa S.G., Taranu N., Bonoli A., Gavrilesu M., (2013), Ecological footprint applied in the assessment of construction and demolition waste integrated management, *Environmental Engineering and Management Journal*, **12**, 779-788.
- UNEP, (2009a), Developing Integrated Solid Waste Management Plan, vol 1, Waste Characterization and Quantification with Projections for Future, United Nations Environmental Programme, Division of Technology, Industry and Economics, International Environmental Technology Centre, Osaka/Shiga, Japan.
- UNEP, (2009b), Developing Integrated Solid Waste Management Plan, vol. 2, Assessment of Current Waste Management and Gaps therein, United Nations Environmental Programme, Division of Technology, Industry and Economics, International Environmental Technology Centre, Osaka/Shiga, Japan.
- Vrancart, (2008), Annual Report for the financial year 2008, (in Romanian), On line at: <http://www.vrancart.ro/index.php?lang=ro&m=12&p=anual>.
- Winkler J., Bilitewski B., (2007), Comparative evaluation of life cycle assessment models for solid waste management, *Waste Management*, **27**, 1021-1031.